

CECONY's 2023 Local Transmission Plan (LTP)

Overview

- NYC and Westchester
- 660 square miles
- 9.3 million people
- 3.4 million customers
- All time system peak
 - 13,322 MW (2013)



LTP Assumptions

- The projected load forecast for the next 10-years:

Year	2023 Reference	2024	2025	2026	2027	2028	2029	2030	2031	2032	2033	2034
Load (MW)	12,990	13,150	13,180	13,150	13,080	13,000	12,960	13,260	13,400	13,570	13,810	14,040
% Growth	-	1.2	0.2	-0.2	-0.5	-0.6	-0.3	2.3	1.1	1.3	1.8	1.7

- Con Edison FIRM Transmission Projects:
 - Y2025: RCC Gowanus – Greenwood Phase Angle Regulated 345/138 kV Feeder
 - Y2025: RCC Goethals – Fox Hills Phase Angle Regulated 345/138 kV Feeder
 - Fox Hills 138 kV Substation rebuild as a Ring Bus
 - Y2028: Brooklyn Clean Energy Hub (BCEH)

Brooklyn Clean Energy Hub

Brooklyn Clean Energy Hub – FIRM Project

- Con Edison will construct a new 345 kV load serving substation in northwest Brooklyn to provide supply to the new Gateway 27 kV Distribution Area Substation
 - The in-service date for this project is summer 2028
- Driven by growing demand in Brooklyn and Queens
 - The existing Brownsville No.1 27 kV Distribution Area Substation cannot meet customer electric demand beginning in 2028
 - The new Gateway 27 kV Distribution Area Substation will transfer existing load from Brownsville No. 1
 - Y2028 Load: about 120 MW
- The designated load serving capability of the BCEH is about 1,900 MW

Brooklyn Clean Energy Hub – FIRM Project

- BCEH will intercept three existing 345 kV feeders (61, 62, and 63) between Farragut and Rainey 345 kV Substations and diverting them into BCEH
- BCEH will be a double ring bus substation
 - Initially with thirteen 345 kV bus sections (expandable to nineteen bus sections)
 - Six bus sections will be utilized for 61, 62, and 63 feeders
 - Five bus sections will be utilized for the 345/138 kV transformer banks
 - The transformer banks will provide sources for 138 kV underground transmission lines that will connect to the Gateway Park 27 kV Distribution Area Substation
 - Two bus sections will remain open (immediately available)
 - Six more breaker additions would create 6 additional bus sections

Brooklyn Clean Energy Hub – FIRM Project

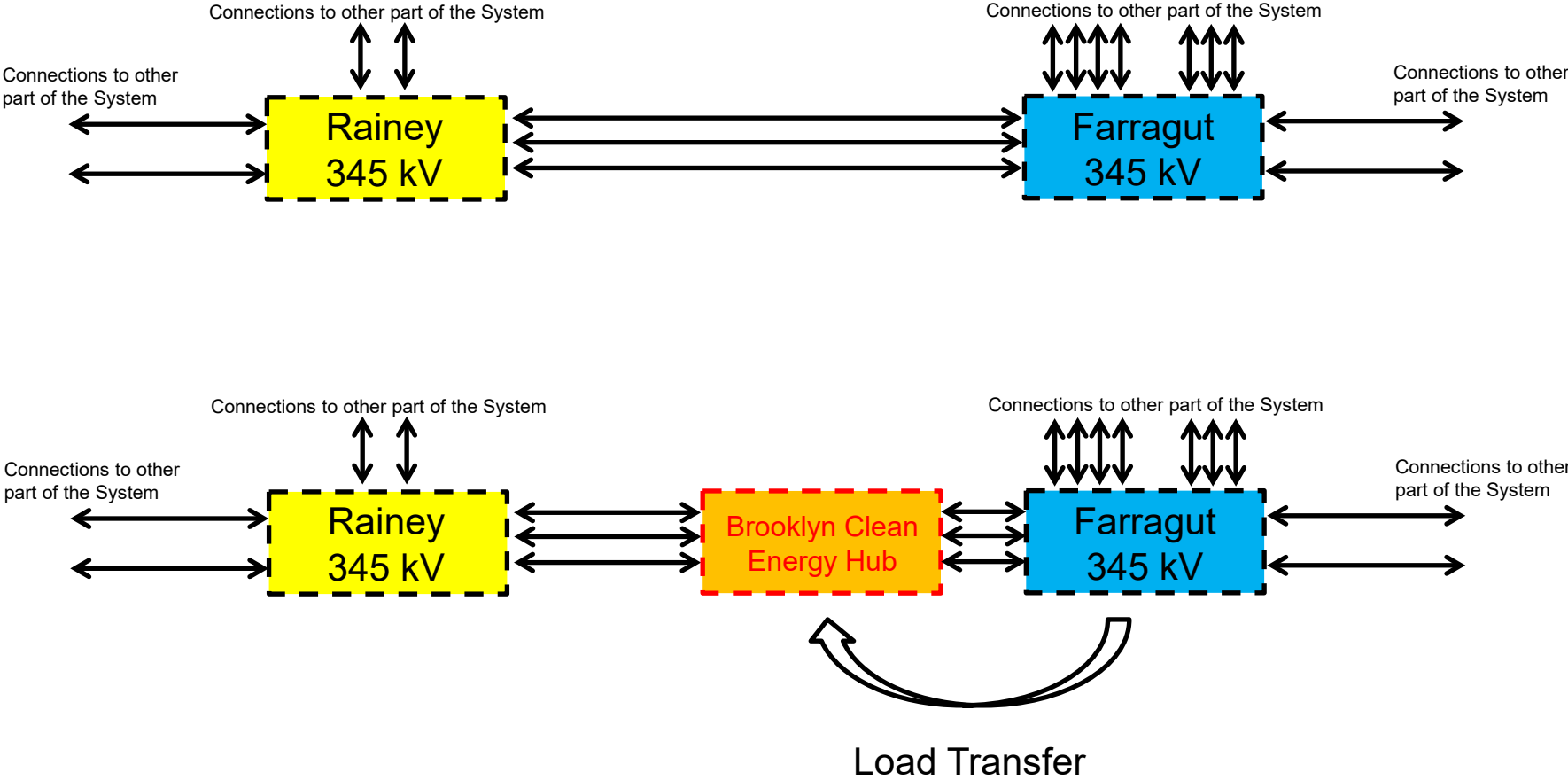

Update to Brooklyn Clean Energy Hub

- New FIRM redesign of BCEH
 - Develops the full potential of the BCEH
 - OSW Capability: up to 6,000 MW
 - 6 Open Bus Positions at BCEH (4,500 MW)
 - 2 Open Bus Positions at Farragut (1,500 MW)
 - Provides additional system resiliency on the NYC 345 kV transmission system
- In-Service data: 2033

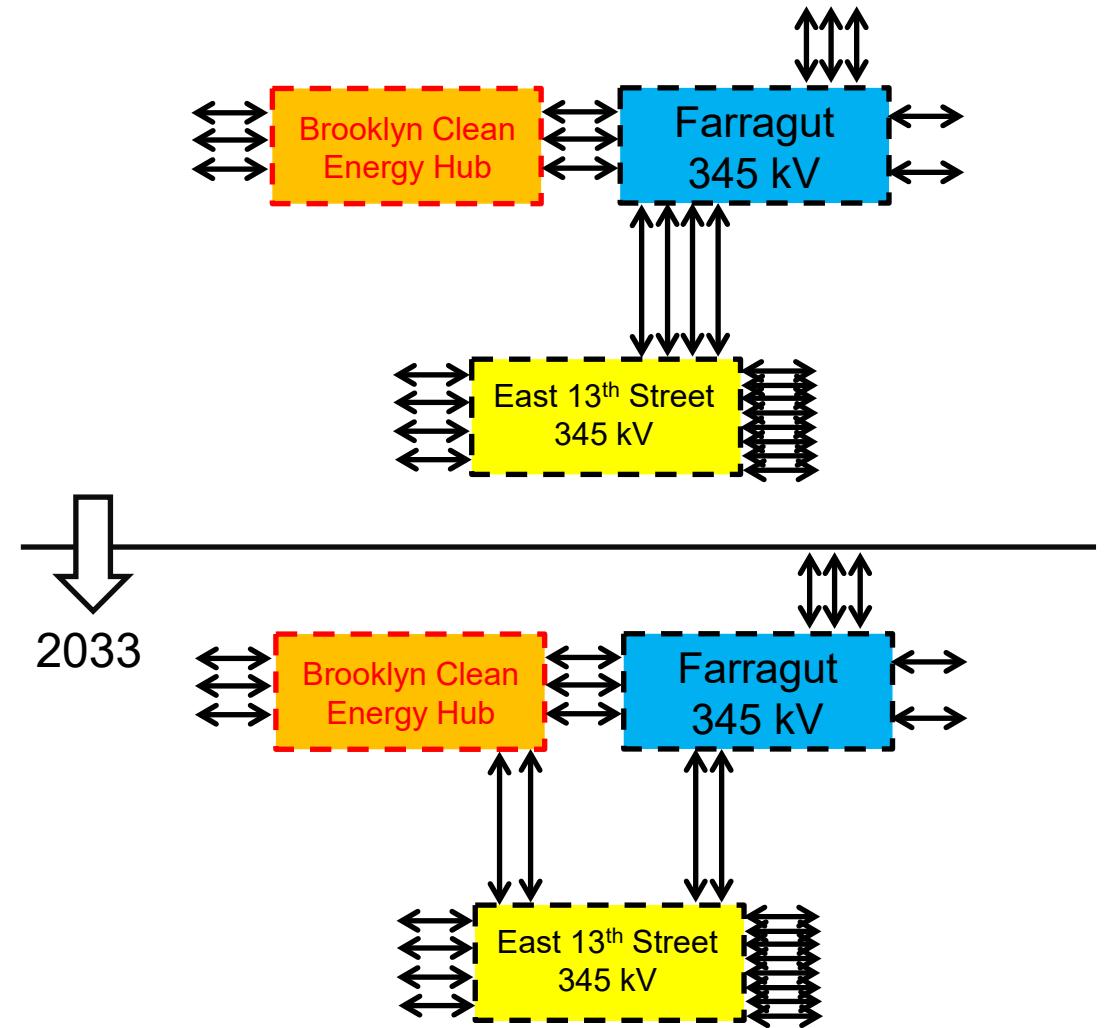

Reliable Clean City (RCC) Eastern Queens

Eastern Queens 138 kV Substation – non-FIRM Project

- Con Edison plans to construct a new 138 kV load serving substation in Eastern Queens to provide supply to the new Idlewild 27 kV Distribution Area Substation
 - The in-service date for this project is summer 2028
- Driven by growing demand in Queens
 - The existing Jamaica 27 kV Distribution Area Substation cannot meet customer electric demand
 - The new Idlewild 27 kV Distribution Area Substation will transfer existing load from Jamaica
 - Y2028 Load: about 170 MW

Eastern Queens 138 kV Substation – non-FIRM Project

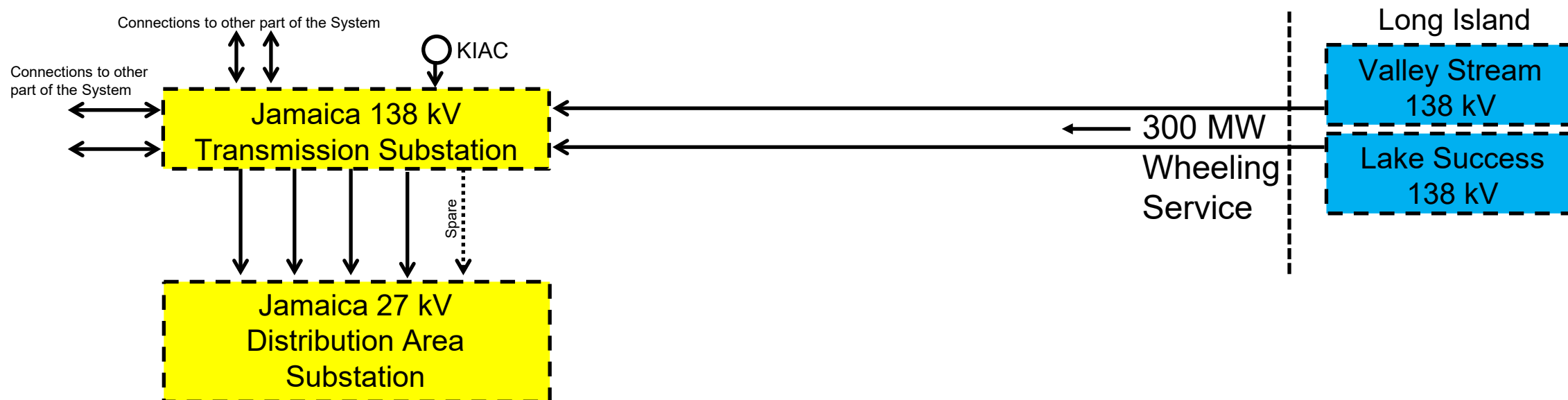

System "as is"

Eastern Queens 138 kV Substation – non-FIRM Project

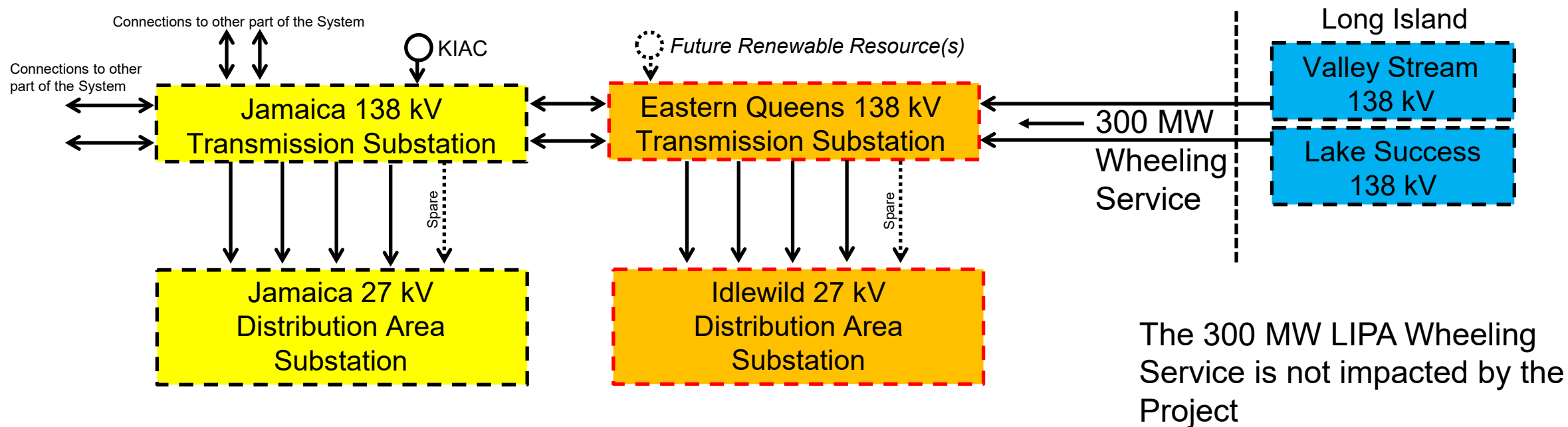

System with the Project

Eastern Queens 138 kV Substation – non-FIRM Project

- The Eastern Queens 138 kV transmission substation provides potential POIs for storage or other clean energy resources
 - Up to 600 MW
- Con Edison filed petition on August 22, 2023
 - ESPWG/TPAS will be update when Con Edison is ready to make the project FIRM

Greenwood Transmission Load Area

Greenwood 138 KV TLA – FIRM Project

- Reliability need has been identified within the Greenwood 138 kV TLA

	Deficiency (MW)	Duration (hours)	Duration
Year 2030	17	6	4 PM - 10 PM
Year 2031	32	8	3 PM - 11 PM
Year 2032	50	9	2 PM - 11 PM
Year 2033	74	10	1 PM - 11 PM

- Solution: Load Transfer
 - Greenwood to be de-loaded by a (138 kV to 345 kV) distribution load transfer to BCEH

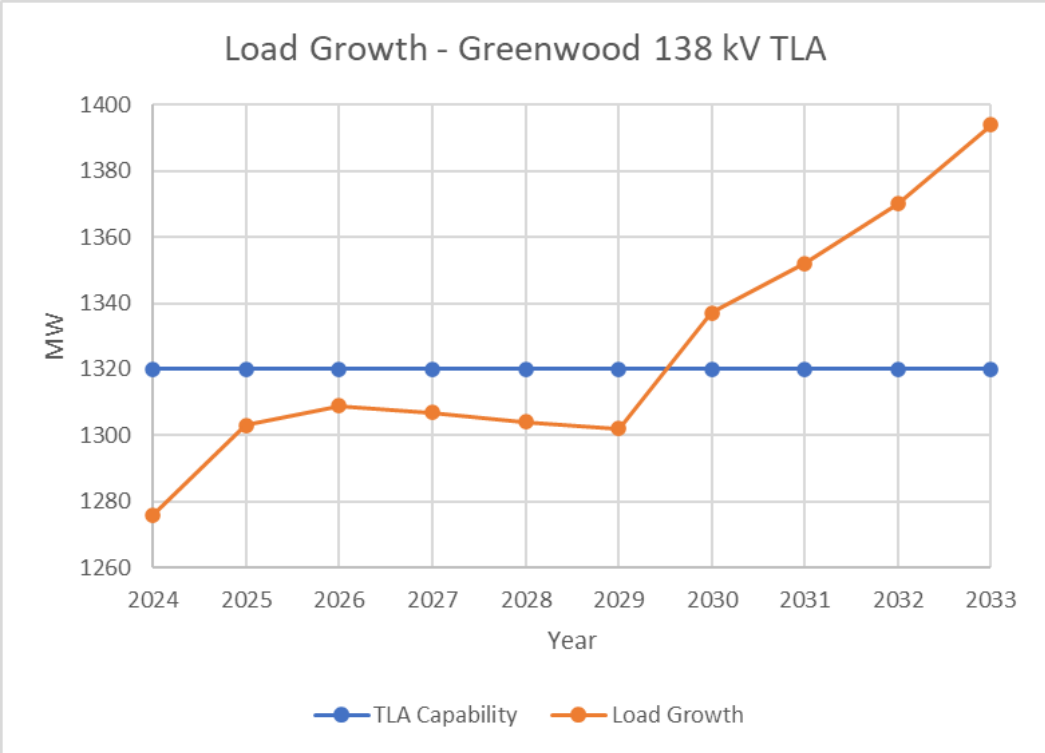

Questions & Answers



Thank You!

Contact

- Interested parties may submit written comments within 30 days to:

Martin Paszek

Section Manager – S&TO System Performance

Con Edison Company of New York, Inc.

4 Irving Place, 13 Floor NW

New York, NY 10003

paszekm@coned.com

(w) 212-460-6415

- CECONY LTP will be posted on its external (public) website:

[Transmission Planning | Con Edison](#)