



LAST REVIEW DATE:
6/22/11

REVIEW CYCLE:
5 Years

SPECIFICATION: **G-2040-9**

TITLE: **REQUIREMENTS FOR THE INSTALLATION OF
GAS BOOSTERS, MICROTURBINES AND
ASSOCIATED SYSTEM PROTECTIVE DEVICES**

VOLUME: **4 and Gas Blue Book**

REVISIONS: (See ★)

- 1) Section 2.0 - Changed "Local Building Code – NYC Department of Buildings" to "New York City Fuel Gas Code."
- 2) Section 3.0 - Added Gas Engineering – New Business.
- 3) Section 4.1 - Reworded for clarity.
- 4) Section 4.2 - Reworded for clarity.
- 5) Section 4.3 - Clarified Gas Engineering to be "Gas Engineering – New Business."
- 6) Section 5.1 - Deleted repetitive wording regarding testing laboratories.
- 7) Section 5.2 - Reformatted. Added reference to magnetic-coupled type boosters. Clarified when explosion-proof motors are required.
- 8) Section 5.3 - New section covering acceptable locations. Renumbered subsequent sections.
- 9) Section 5.4 - Added reference to stainless steel braided hose connections.
- 10) Section 5.5 (A) - Added requirement for check valve to be Con Edison approved.
- 11) Section 5.5 (B)(1) - Added requirement for pressure switch to be Con Edison approved.
- 12) Section 5.5 (B)(2) - Added paragraph covering alternate location of low pressure gas switch. Renumbered subsequent paragraph.

(Continued)

- 13) Section 5.5 (C) - Reworded. Deleted "mercury-free" verbiage.
- 14) Section 5.10 (B)(1) - Added requirement for the one-line drawing to specify the size and location of all piping, the type of connection and the size and configuration of bypass piping. Added note regarding alternate location of low pressure gas switch.
- 15) Section 5.11 - Revised section title in (A). Reworded (A) and (B) for clarity.
- 16) Section 6.0 - Clarified requirements when microturbines are installed.
- 17) Section 7.0 - Updated "References" section.
- 18) Section 8.0 - Updated to reflect revised title of Appendix B.
- 19) Appendix A - Reformatted item 1. Added (B). Added area for "Additional Info."
- 20) Appendix B - Revised title. Reformatted Field Verification Checklist and reworded items 5, 8 and 9 for clarity.
- 21) Dwg #311296 - Added flex connector and Note 5.



Gas Operations Standards

**TITLE: REQUIREMENTS FOR THE
INSTALLATION OF GAS BOOSTERS,
MICROTURBINES AND ASSOCIATED
SYSTEM PROTECTIVE DEVICES**

TABLE OF CONTENTS

<u>SECTION</u>	<u>TITLE</u>	<u>PAGE</u>
1.0	SCOPE	2
2.0	LEGAL REQUIREMENTS	2
3.0	ORGANIZATIONS APPLICABLE	2
4.0	RESPONSIBILITIES	2
5.0	GAS BOOSTER INSTALLATIONS	2
6.0	MICROTURBINE INSTALLATIONS	7
7.0	REFERENCES	7
8.0	ATTACHMENTS	7

ENVIRONMENTAL REVIEW BY: A. Liguori		SAFETY REVIEW BY: A. Liguori		
PREPARED BY:	APPROVED BY:	DATE:	VOLUME: 4 and Gas Blue Book	PAGE 1 OF
S. Yapchanyk	Frank Ciminiello Chief Gas Distribution Engineer	6/22/11	Application and Design; Gas Blue Book	7 PAGES



**TITLE: REQUIREMENTS FOR THE
INSTALLATION OF GAS BOOSTERS,
MICROTURBINES AND ASSOCIATED
SYSTEM PROTECTIVE DEVICES**

1.0 **SCOPE**

This specification covers the requirements for the installation of gas boosters, microturbines and associated system protective devices to be installed by the customer.

★ 2.0 **LEGAL REQUIREMENTS**

New York City Fuel Gas Code, NYC Department of Buildings and in Westchester County the municipality having jurisdiction.

Other Codes (as they apply).

★ 3.0 **ORGANIZATIONS APPLICABLE**

Westchester, Manhattan, Bronx and Queens Gas Operations; Gas Engineering – New Business; Energy Services.

4.0 **RESPONSIBILITIES**

★ 4.1 The Energy Services Representative shall indicate on the electronic Service Determination Request in Logica/work management system, each item of customer utilization equipment that will require gas pressure in excess of 4 inches water column (w.c.).

★ 4.2 Energy Services shall be responsible for performing field checks of the booster installation and completing Appendix B.

★ 4.3 Gas Engineering – New Business shall determine the service size.

4.4 The customer, the customer’s engineer or customer’s contractor shall be responsible to have the booster manufacturer’s representative prepare the submittals indicated in Section 5.9 of this specification.

5.0 **GAS BOOSTER INSTALLATIONS**

★ 5.1 Con Edison is required to supply a minimum gas pressure of 4 inches w.c. at the head of service. A gas booster may be installed by the customer when Con Edison-supplied gas pressure is not sufficient to supply new gas



NUMBER:	DATE:	VOLUME: 4 and Gas Blue Book	PAGE 2
G-2040-9	6/22/11	Application and Design; Gas Blue Book	OF 7 PAGES



**TITLE: REQUIREMENTS FOR THE
INSTALLATION OF GAS BOOSTERS,
MICROTURBINES AND ASSOCIATED
SYSTEM PROTECTIVE DEVICES**

5.0 **GAS BOOSTER INSTALLATIONS** (Continued)

utilization equipment. Only gas boosters listed by a nationally recognized testing laboratory (i.e., UL or CSA) shall be used with natural gas.

- ★ 5.2 A) For **indoor installations**, the gas booster shall be hermetically-sealed.
 - 1) Where the booster design is of the direct-drive type with motor enclosed within the booster canister, the motor shall be explosion-proof.
 - 2) Where the booster design is of the magnetic-coupled type with an external motor, the motor need not be explosion-proof, unless it will be installed in a NEMA 7 location.
- B) For **outdoor installations**, a non hermetically-sealed booster may be used.

★ 5.3 Acceptable locations for gas boosters shall be determined by local codes and authorities having jurisdiction.

★ 5.4 The gas booster shall be mounted and installed as per the manufacturer's specifications and/or drawings. This may include the installation of stainless steel braided hose connections.

5.5 **Required Protective Equipment**

- ★ A) **Check Valve**

A check valve shall be installed by the customer between the gas meter and the gas booster as shown in drawing 311296, attached. The check valve is required to prevent flow back through the gas meter and into the Con Edison gas distribution system. The booster manufacturer or its authorized representative shall specify the size and minimum distance between the check valve and the booster inlet. This information shall be indicated on Line 16 of Appendix A. See Section 5.10. Only Con Edison-approved check valves shall be used. See Section 5.5 (C).



NUMBER:	DATE:	VOLUME: 4 and Gas Blue Book	PAGE 3
G-2040-9	6/22/11	Application and Design; Gas Blue Book	OF 7 PAGES



**TITLE: REQUIREMENTS FOR THE
INSTALLATION OF GAS BOOSTERS,
MICROTURBINES AND ASSOCIATED
SYSTEM PROTECTIVE DEVICES**

5.0 **GAS BOOSTER INSTALLATIONS** (Continued)

B) Low Pressure Switches

- ★ 1) A low pressure switch with a 1/4" diameter manometer test connection (see drawing 311296) shall be installed between the gas meter and the check valve, as close as possible to the gas service point of entry. The switch shall be set and wired to shut the booster off at a minimum of 3 inches w.c. The booster manufacturer or its authorized representative shall specify the make, model and the NEMA rating of the switch on Line 14 of Appendix A. Only Con Edison approved low pressure switches shall be used. See Section 5.5 (C).

- ★ 2)
 - a) Where installation of the low pressure gas switch near the gas service point of entry is impractical or prohibitive due to the location of the gas service head valve relative to that of the gas booster, the switch may be installed at an alternate location if approved by the booster manufacturer or authorized representative **and the local Gas Distribution Services (GDS) Department**. See Note in Section 5.10 (B).
 - b) If an alternate location is approved, two permanently engraved signs shall be installed: one at the booster, indicating the location of the low pressure gas switch and one at the gas head of service indicating the location of the gas booster and the location of the low pressure gas switch.

- 3) A second low pressure switch may be installed on the outlet pipe of the gas booster. This second switch is at the customer's option and may be used to alarm upon booster failure. This switch need not be a Con Edison-approved switch.

- ★ C) Con Edison approved check valves and low pressure switches are listed in Table XVII of Con Edison's "Requirements for Gas Service Installations" (Gas Blue Book).



NUMBER:	DATE:	VOLUME: 4 and Gas Blue Book	PAGE 4
G-2040-9	6/22/11	Application and Design; Gas Blue Book	OF 7 PAGES



**TITLE: REQUIREMENTS FOR THE
INSTALLATION OF GAS BOOSTERS,
MICROTURBINES AND ASSOCIATED
SYSTEM PROTECTIVE DEVICES**

5.0 GAS BOOSTER INSTALLATIONS (Continued)

5.6 Branch Supply

Supply of gas to equipment not requiring "boosted pressure" shall be located on the upstream side of the check valve. Branch supply may be connected through the same meter or separate meter(s) depending on the service classifications involved. See drawing 311296-1 attached.

5.7 Piping

Piping from the gas point of entry (POE) to the booster(s) shall be designed by the customer or the customer's authorized representative so as to allow a maximum pressure drop of 1 inch w.c. (excluding the gas meter).

5.8 By-Pass

Some booster installations may require the installation of a by-pass. A by-pass shall be installed when specified by the booster manufacturer or its authorized representative. When required, the by-pass shall be installed downstream of the check valve.

5.9 Re-circulation Loop and Heat Exchanger

Some booster installations may require a re-circulation loop with a heat exchanger and associated sensors and controllers. Such equipment shall be installed when specified by the booster manufacturer or its authorized representative. In general, this arrangement will be called for to keep the booster motor cool under low flow conditions.

5.10 Submittals

The booster manufacturer or its authorized representative shall submit to the Con Edison Energy Services Representative, the following:

- A) a completed Gas Booster Design Data Sheet (Appendix A of this specification).



NUMBER:	DATE:	VOLUME: 4 and Gas Blue Book	PAGE 5
G-2040-9	6/22/11	Application and Design; Gas Blue Book	OF 7 PAGES



**TITLE: REQUIREMENTS FOR THE
INSTALLATION OF GAS BOOSTERS,
MICROTURBINES AND ASSOCIATED
SYSTEM PROTECTIVE DEVICES**

5.0 **GAS BOOSTER INSTALLATIONS** (Continued)

- ★ B) a job specific one-line drawing of the proposed booster installation. The drawing shall indicate:
 - 1) the location and size of all piping, isolation valves, check valves (including the minimum distance from the booster inlet), pressure switches, pressure gauges, boosters, gas meters; and the type of connection (e.g. flanged; threaded; welded; or stainless steel braided hose.)

NOTE: If the low gas pressure switch is shown on the one-line sketch to be in a location **other than** near the gas service point of entry [See 5.5 (B)(2)], the local GDS Department shall be contacted by the ESR for concurrence.

- 2) the size and configuration of by-pass piping, re-circulation loop, and heat exchanger, if required.

5.11 Field Verification

- ★ A) Preliminary Field Check
Prior to issuing a turn-on request for the gas meter(s) that feeds the gas booster, the Company's Energy Services Representative shall perform the field checks called for in Appendix B of this specification.
- ★ B) Deficiencies
 - 1) If the field checks reveal any deficiencies, the Energy Services Representative shall notify the customer or customer's authorized representative. The turn-on request for gas meters that feed the gas booster shall not be issued until all deficiencies are corrected.
 - 2) Gas shall not be supplied to a booster that lacks the required protective equipment called for in Section 5.5 A) & B). In such case, in lieu of shutting down or denying gas to the entire building, the booster inlet valve may be closed and locked so that other branches of gas distribution piping not fed by the booster may be or remain supplied.



NUMBER:	DATE:	VOLUME: 4 and Gas Blue Book	PAGE 6
G-2040-9	6/22/11	Application and Design; Gas Blue Book	OF 7 PAGES



**TITLE: REQUIREMENTS FOR THE
INSTALLATION OF GAS BOOSTERS,
MICROTURBINES AND ASSOCIATED
SYSTEM PROTECTIVE DEVICES**

★ 6.0 **MICROTURBINE INSTALLATIONS**

Gas boosters associated with microturbine installations are subject to all requirements of this specification including the Con Edison-approved check valve and low-pressure switch called for in Section 5.5. These requirements will not be waived even if microturbine units are supplied with integral check valves and low pressure switches.

★ 7.0 **REFERENCES**

Table XVII of Con Edison "Requirements for Gas Service Installations" ("Gas Blue Book")

★ 8.0 **ATTACHMENTS**

Appendix A: Gas Booster Design Data Sheet

Appendix B: Field Verification Checklist

Drawing No. 311296 "Typical Gas Booster Installation"



NUMBER:	DATE:	VOLUME: 4 and Gas Blue Book	PAGE 7
G-2040-9	6/22/11	Application and Design; Gas Blue Book	OF 7 PAGES

★ Appendix A
Gas Booster Design Data Sheet
To Be Completed By the Booster Manufacturer or Its Authorized Representative

Project Address (POE): _____

LOAD & PIPING INFORMATION

- ★1. A) Total # of Boilers _____ Total CFH (Min) _____ (Max) _____
 B) # and Type of Other Gas-Fired Appliances _____ - Total CFH (Min) _____ (Max) _____
- 2. Gas Service Diameter (From Con Ed Form 2-80) _____
- 3. Gas Meter Size & Type (From Con Ed Form 2-80) _____
- 4. Gas Pressure Available at Booster Inlet _____
 (4" W.C. @ Head of Service Minus Pressure Losses.
 Allow 0.5" W.C. For Pressure Drop Through Meter)
- 5. Gas Pressure Required at Manifold Inlet _____
- 6. Discharge Piping Diameter _____
- 7. Total Equivalent Length of Discharge Gas Piping Including Fittings _____
- 8. Total Discharge Piping Pressure Loss _____

★ **ADDITIONAL INFO**

BOOSTER / EQUIPMENT INFORMATION

- 9. Mfr _____ Model _____ Flow Capacity (CFH) _____ NEMA Location _____
- 10. Booster Inlet Size _____ Outlet Size _____
- 11. Booster Motor HP _____ Voltage _____ Ph _____ Hz _____
- 12. Booster Differential Pressure (W.C.) _____
- 13. Total Discharge Pressure (W.C.) _____
 (Differential Pressure + 4" W.C.)
- 14. Low Pressure Switch (See Note*) Make _____ Model _____ NEMA _____
- 15. Control Panel Make _____ Model _____ NEMA _____
- 16. Check Valve (See Note*) Mfr _____ Size _____ Min. Allowable Distance To Booster Inlet _____
- 17. Manifold Req'd: Y/N _____ If Yes: # of Valves _____
- 18. Heat Exch'r Req'd: Y/N _____ If Yes: Piping Size _____ Check Valve Size _____

Submitted By: _____ Date: _____ Rev # _____

Company: _____ Phone: _____
 (Booster Mfr or Authorized Representative)

_____/_____/_____/_____
 Name of Con Edison ESR / Phone / Fax / E-Mail Address

*Note: Equipment must be listed in Table XVII of the "Requirements For Gas Services" (Gas Blue Book)

★ Appendix B

Field Verification Checklist

To be completed by the Company's Energy Services Rep prior to release of the gas meters.

Project Address (POE): _____

GAS BOOSTER			
		Yes	No (Indicate Action Taken)
1	Has the gas booster been installed?		
2	Does the make and model of the booster match the booster specified on Appendix A (Line 9) ?		
PIPING			
3	Is the size of the booster piping (from the check valve to the booster inlet) in accordance with the booster manufacturer's one-line sketch for this job?		
4	Have the booster isolation valves (if called for on the one-line sketch) been installed? [Note: these need <u>not</u> be Con Edison approved valves.]		
★5	If the one-line sketch calls for by-pass lines or re-circulating lines, have they been installed in accordance with the sketch?		
LOW PRESSURE SWITCH			
6	Has the low pressure switch been installed?		
7	Does the make, model and NEMA rating of the switch match the switch specified on Appendix A (Line 14) ?		
★8	Is the switch located between the gas meter and the check valve at the booster inlet as close as possible to the gas service POE?		
★9	Where there is a branch supply to other gas equipment not requiring boosted pressure, is the switch located on the downstream side of the branch connection as shown on Con Ed drawing 311296-1, attached?		
CHECK VALVE			
10	Has the check valve at the booster inlet been installed?		
11	Does the make, model, and size of the check valve match the check valve specified on Appendix A (Line 16) ?		
12	Is the check valve located at least the minimum distance away from the inlet of the booster as indicated on Appendix A (Line 16) ?		
13	Does the arrow on the check valve point toward the booster?		

Name of C.E. Energy Services Representative : _____

Date and Time of Inspection : _____ / _____

311296

REVISIONS

M. BALDOVIN 3/8/06	1
-----------------------	---

REVISED NOTES.

RAJ 5/17/06

M. BALDOVIN 6/22/11	2
------------------------	---

ADDED FLEX CONNECTOR AND NOTE 5.

D.J. 6/22/11

NOTES:

- 1- THIS VALVE MAY BE OMITTED IF THE BOOSTER IS IN CLOSE PROXIMITY TO ANOTHER DEDICATED SHUTOFF VALVE. THE SERVICE HEAD VALVE OR METER VALVE MAY REPLACE THE VALVE UPSTREAM OF THE BOOSTER. THE GAS TRAIN VALVE MAY REPLACE THE VALVE DOWNSTREAM OF THE BOOSTER. THIS NEED NOT BE A CON EDISON APPROVED VALVE.
- 2- CON EDISON APPROVED EQUIPMENT. SEE CON EDISON "REQUIREMENTS FOR GAS SERVICES" (TABLE XVII)
- 3- THE LOW PRESSURE SWITCH SHALL BE WIRED TO THE BOOSTER CONTROL PANEL. THE SWITCH SHALL HAVE A MANUAL RESET AND BE SET TO OPEN AT 3" WC TO SHUT THE BOOSTER OFF.
- 4- THIS VALVE MAY BE OMITTED IF THE LINE IS FED FROM A DEDICATED SERVICE AND APPROVED IN WRITING BY CON EDISON.
- 5- FLEXIBLE CONNECTOR (E.G. STAINLESS STEEL BRAIDED HOSE) IF SPECIFIED BY THE BOOSTER MFR OR REPRESENTATIVE.

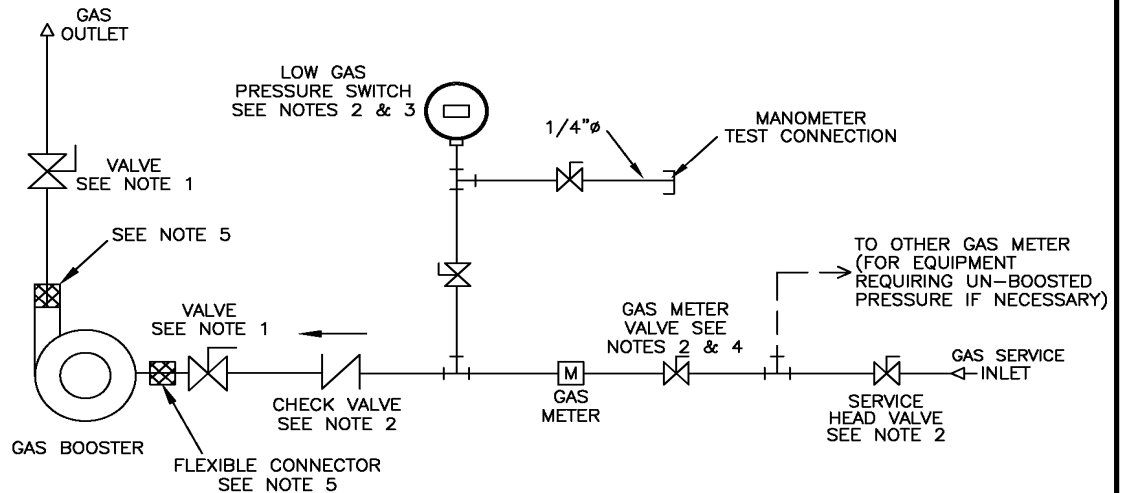

REFERENCE SPECIFICATION G - 2040

TYPICAL GAS BOOSTER INSTALLATION	
CONSOLIDATED EDISON COMPANY OF N.Y., INC. GAS ENGINEERING DEPT	
DATE 1/7/98	DWG. NO. 311296 REV. 2
LAST REV. 6/22/11	