



WELCOME TO CON EDISON

**Interconnection Guide for Non-Wire Solutions (NWS)
Brooklyn Queens Demand Management (BQDM) 2022 - 2023
Prescriptive Energy Storage System Program**

Version 1 / June 2022



Table of Contents

Introduction	3
Standardized Interconnection Requirements (SIR) Process Overview	4
Project Management, Communication, & Coordination.....	4
DER Interconnection Design Options for Service.....	5
References.....	10

DISCLAIMER

This document is for informational, general guidance purposes only and Consolidated Edison Company of New York shall not be held liable for indirect, special, incidental, punitive or consequential damages of any kind including loss of profits, arising under or in connection with the use of this information guide.

Introduction

- This guide has been prepared by Con Edison Company of New York, Inc. (“Con Edison” , the Company/Utility) for customers who are planning to install Distributed Energy Resources (DER) and seeking to participate in the 2022 Non-Wire Solutions (NWS) Brooklyn Queens Demand Management (BQDM) Prescriptive Battery Energy Storage System (BESS) program. This guide provides a high-level, non-technical introduction to the sequence of events involved in the construction of *a high tension substation or 460V installation, and the interconnection process for DER.*
- Participant must interconnect in compliance with the requirements and terms and conditions set forth in the [New York State Standardized Interconnection Review](#). Projects must follow the codes, standards, and requirements set forth by all AHJs including New York State Standard Interconnection Requirements, New York City or local municipalities, the Department of Buildings, Department of City Planning, the Fire Department of New York, and any other relevant agency that oversees the proper zoning, permitting, construction, and operation process of BESS.
- Participant must follow Con Edison requirements and specifications as stipulated in the [Electric Blue Book](#) and applicable [forms and documentation for Private Generation Interconnection](#).
- Applicants looking to participate in this program will need to adhere to the Non-Wires Solutions Program Agreement requirements.
- To ensure BESS are operationally available on peak load days when potential network contingencies may also occur, Con Edison is requiring all BESS to meet certain interconnection reliability design standards based on the site location. Projects that do not interconnect at the required local reliability of the network will be ineligible for any incentive under this program.

For tariff related concerns, please review the [Con Edison Public Service Commission \(PSC\) approved tariff](#) and Federal Energy Regulatory Commission Open Access Transmission Tariff (FERC-OATT) [tariff](#). For more information please review the [Con Edison rates and tariffs website](#).

- *This guide is a companion to Con Edison’s Company specifications (listed below), which provides detailed technical requirements. This document is not intended as a design specification or an instruction manual.*
 - [EO-2022](#) - “General Specification for High Tension service”
 - [EO-5051](#) - “Design and Construction of 265/460V Transformer Vault and Network Compartments by Contractors”

Utility Process for Non-Wire Solutions (NWS) Brooklyn Queens Demand Management (BQDM) 2022 - 2023 / Version 1/ June 2022

- o [EO-10215](#) - “Interconnection Requirements for Distributed Energy Resources (DER) To High Tension Non-Network Distribution”

[EO-2115](#) - “Handbook of General Requirements for Electrical Service to Dispersed Generation Customers”

SIR Process Overview

Projects must adhere to the New York Standardized Interconnection Requirements ([SIR](#)) process

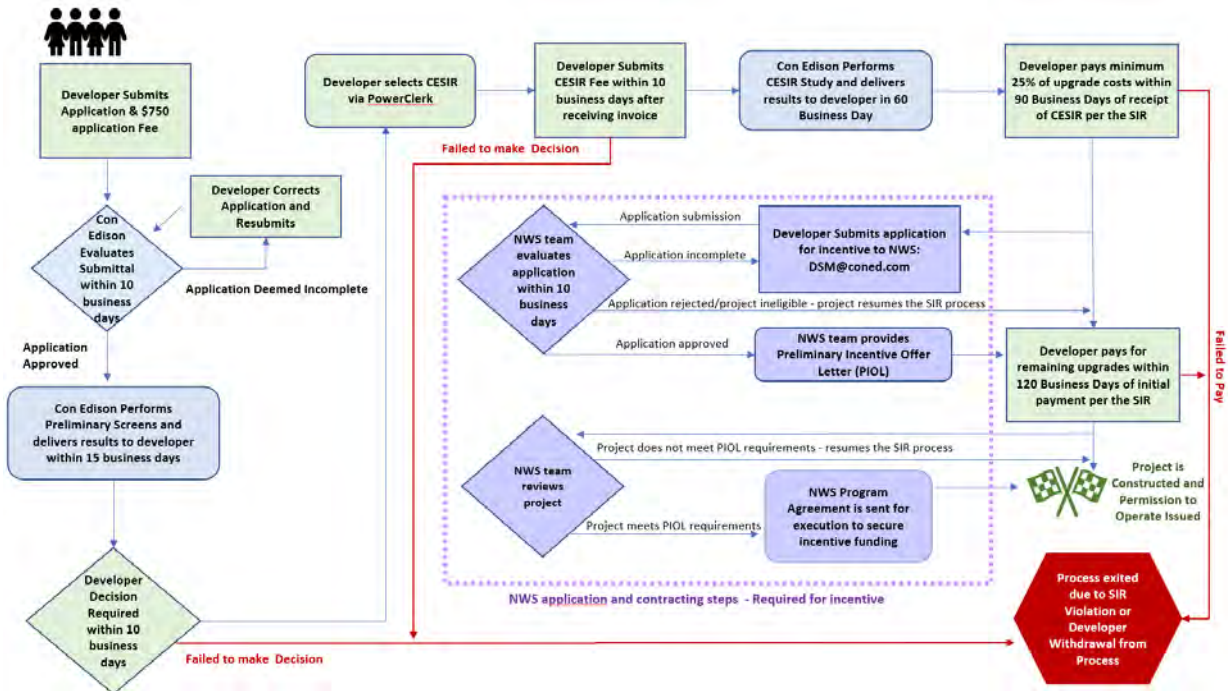

Project Management, Communication, & Coordination

The Company will appoint a Customer Project Manager (CPM) who will act as the liaison between the customer and the Company. The CPM will work to clearly communicate the requirements of each department to the customer and to direct the customer’s questions to the appropriate internal department that can provide the answer.

While the customer may delegate the daily management of the project to a consultant, we encourage the customer to periodically meet with the CPM to discuss the progress of the project.

Several departments within the Company will be involved in the process of approving and energizing a new service with a DER project. Some departments will evaluate the customer’s design while others will review system updates to provide service. Your CPM will guide you through Con Edison’s internal process. For example, the CPM will work so that the customer is

Utility Process for Non-Wire Solutions (NWS) Brooklyn Queens Demand Management (BQDM) 2022 - 2023 / Version 1/ June 2022

aware of important scheduling constraints. The company does not schedule planned or new business work during the Summer season that requires medium voltage feeder (circuit) outages, as this is the period of peak electricity demand. Similarly, scheduled/planned work may be impacted by system emergencies that may delay necessary feeder outages for your project. Through the CPM, the customer and company will work together to ensure that tasks are scheduled and completed with minimal delays.

Following issuance of the POL for the BQDM BESS Program, a member of the NWS team will be appointed to work alongside the CPM as well as the customer and/or customer's consultant to support the project. The NWS contact will ensure the project moves forward in accordance with the BQDM BESS program requirements, and support wherever possible, in achieving the necessary goals to receive the incentive. The NWS contact will provide guidance on the incentive program requirements and attend meetings, where necessary, with the customer and customer's consultant, CPM and other departments. The CPM will remain the primary point of contact for items related to the project's interconnection.

A visual representation of the role between the customer and/or customer's consultant, the CPM, and NWS contact is shown below.

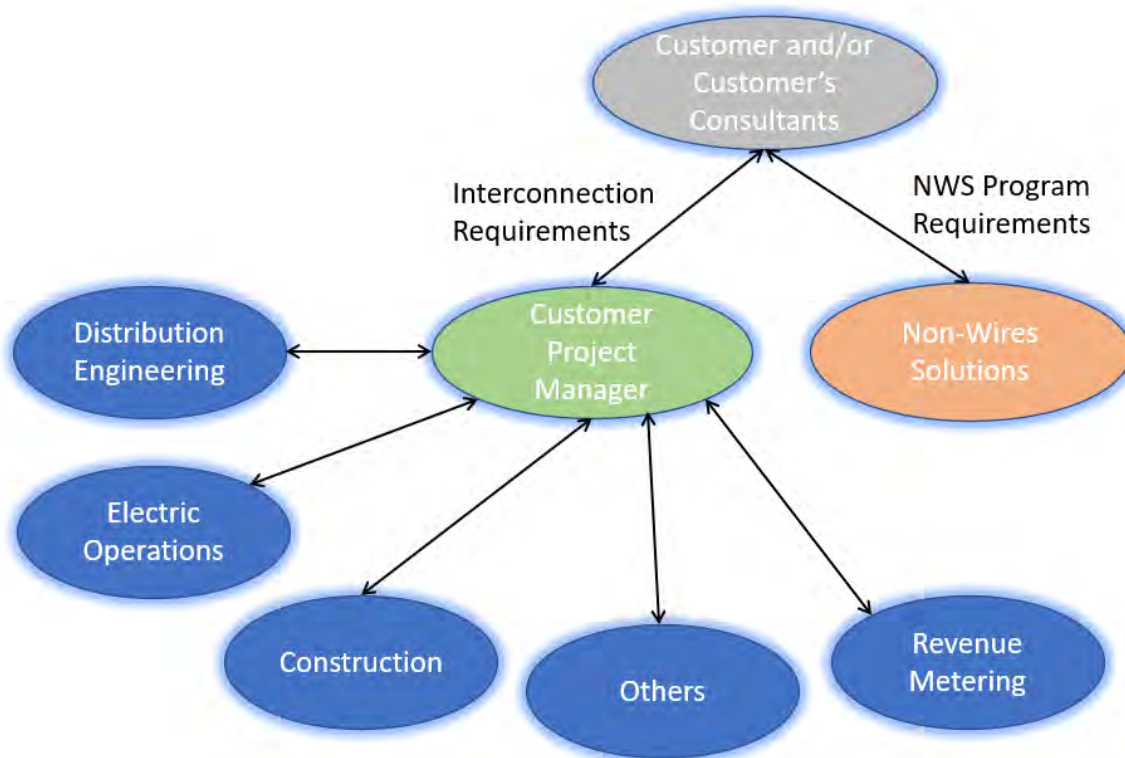

DER Interconnection Design Options for Service

For most interconnections of DERs, the voltage level, configuration, and design will be dictated by the type of distribution system to which it is connected. Con Edison evaluates the design and construction of the substation or service so that it will not have an adverse impact on the electric

Utility Process for Non-Wire Solutions (NWS) Brooklyn Queens Demand Management (BQDM) 2022 - 2023 / Version 1/ June 2022

distribution system. The Company typically extends, reinforces, adds and/or adjusts equipment as needed to safely and reliability provide service. The Company may extend service to a manhole, splice chamber, vault, or pole at the customer property line. The Company does not allow construction of dedicated distribution feeder lines for DER projects. The Company's customer engineering department determines if 460V, High Tension or Non-Network service is required in accordance with the Company's specifications and tariff rate.

The Company owns and maintains its feeders up to the property line manhole, splice chamber, vault, or pole, and the customer will design, install, own, operate, and maintain all equipment from the property line termination point (manhole, splice chamber, vault, or pole), including cables, circuit breakers, transformers, and associated equipment.

The city of New York prevents non-emergency street excavations during the Winter holiday period to minimize traffic disruptions. The Company does not typically perform non-emergency work on primary feeders between May 15 and September 15. Customer property line manholes need to be completed before the ducts can be built for the extension of primary feeders to the customer. The customer should ensure construction of property line manholes are completed in time to allow the Company to build the necessary ducts before the aforementioned times.

The customer is expected to understand and comply with all applicable local, state, and federal requirements to build their facility. The Company cannot waive any requirements of governmental oversight entities. The Company works with the customer to select a convenient position for the Point of Entry (manhole, splice chamber, vault, or pole) to minimize the amount of street construction needed to extend service to the customer.

DER Up to 5 MW and 460V Service

- Projects up to 5 MW range may require 460V installations. The Company's customer engineering department determines if 460V service is required in accordance with the Company's specifications and tariff rate.
- The customer will be required to design, procure, and install the 460V installation to meet all applicable codes, laws, and Company specifications.
- New service requests occur in two phases:
 - Phase 1- Submittal, design and acceptance of DER facilities
 - Phase 2- Space allocation/ DOT process for acceptance of the customer's 460V installation
- Services requiring installation of transformers are complex and generally require 18-24 months from the New York City Department of Transportation (NYCDOT) initial approval/reception of space allocation drawings to completion. This time frame provides 8-10 months for design and 10-14 months for construction. The amount of time for installations may vary and the schedule is driven by the customer.
- **Figure 1** illustrates a 460V installation.

Utility Process for Non-Wire Solutions (NWS) Brooklyn Queens Demand Management (BQDM) 2022 - 2023 / Version 1/ June 2022

- There is a collector bus which parallels the generating equipment.
- The network protectors and associated relays provide protection and isolation from faulted equipment.
- Loads can continue to be served uninterrupted. Each takeoff supplies equipment that is independent of the other takeoffs.

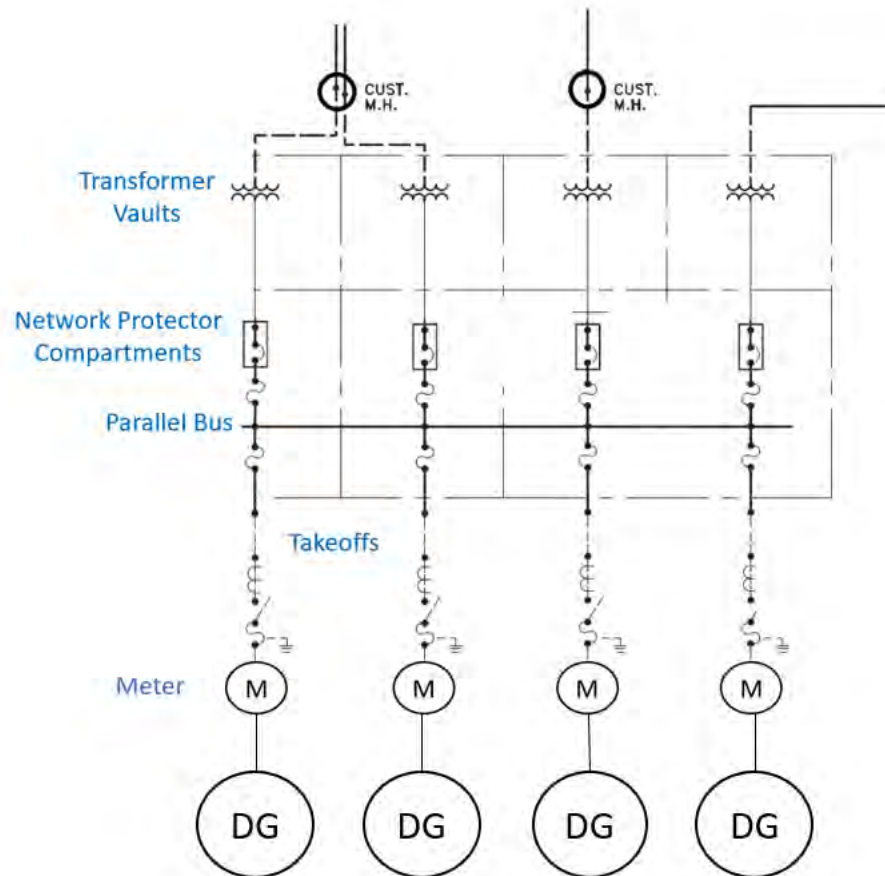

Figure 1 – Example of a 460V Installation

DER for existing High-Tension Service Customers

- For existing High-Tension service customers, the Company may require high tension service. Con Edison provides 3- Phase, high tension service customers at a nominal voltage of 13kV, 27kV or 33kV depending on location. Con Edison does not typically allow projects of this size on the Company's 4kV system.
- High tension services generally require 18-24 months from receipt of the application to completion. This time frame provides 8-10 months for design and 10-14 months for construction. The amount of time for installations may vary and the schedule is driven by the customer.
- The customer will be required to design, procure, install and operate the high tension installation to meet all applicable codes, laws, and Company specifications (See Figure 2).
- New service requests occur in two phases:

Utility Process for Non-Wire Solutions (NWS) Brooklyn Queens Demand Management (BQDM) 2022 - 2023 / Version 1/ June 2022

- Phase 1- Submittal, design and acceptance of DER facilities.
- Phase 2- Design & acceptance of the customer's high tension facilities

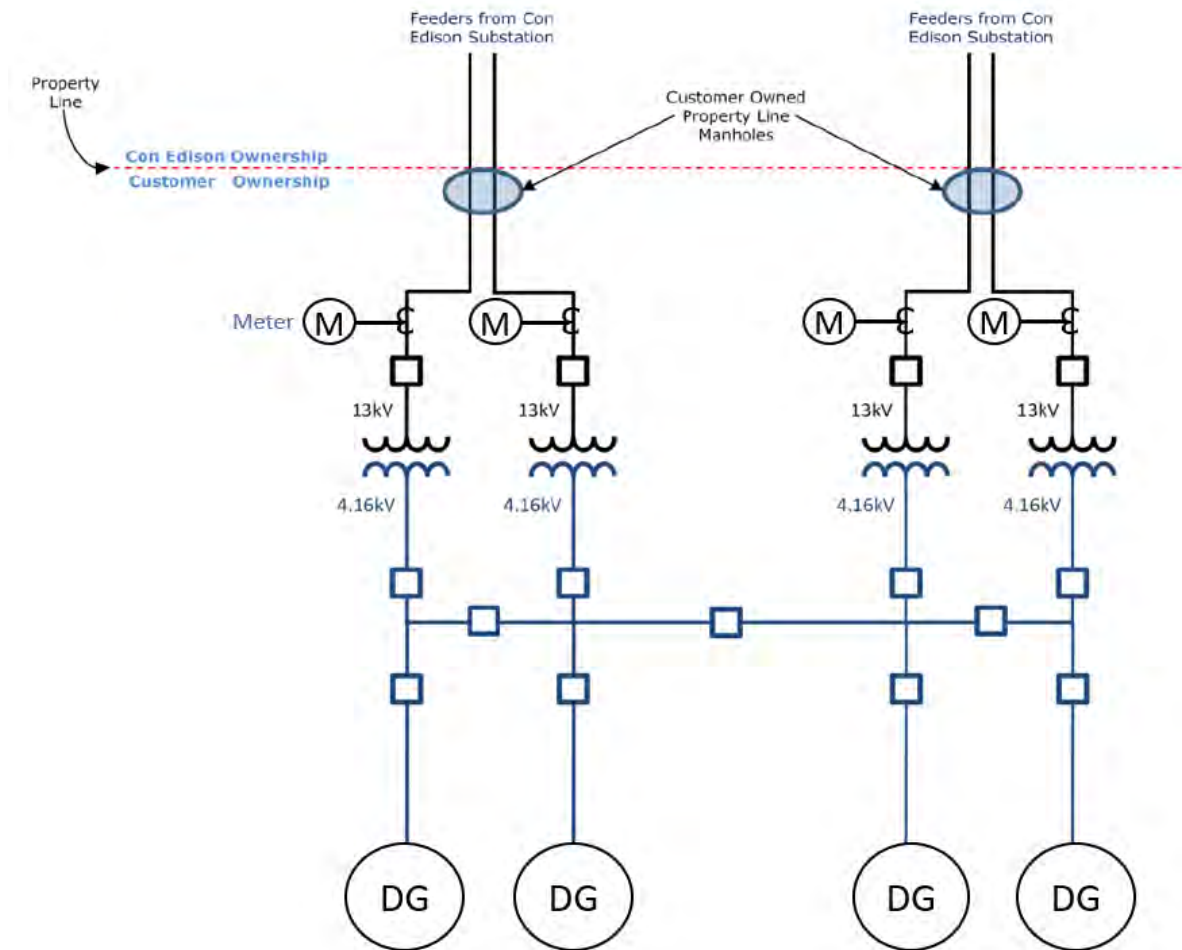

Figure 2 - Example of a parallel (4) Feeder High Tension Service

- Figure 2 illustrates a parallel (4) feeders high tension service.
 - In this configuration, a customer collector bus parallels generating equipment. In the event of a feeder failure, relay protection isolates and protects the system from faulted equipment.
 - This configuration allows a large generator(s) and/or load to continue to be served uninterrupted. Depending on size of generation connected, between two and six feeders may be required.
 - Other considerations such as the “contingency design” and the paralleling and reliability requirements can impact the number of primary distribution feeders and the complexity of the design requirements. Refer to EO-2022 & EO-2115 for technical details.

Non-network

- For Non-network Projects, the Company may provide a service to High Tension Metering Equipment (HTME) under EO-10215.
- The customer will be required to design, procure, install the HTME installation to meet all applicable codes, laws, and Company specifications.
- New service requests occur in two phases:
 - Phase 1- Submittal, design and acceptance of DER facilities
 - Phase 2- Review and Approval of the customer's HTME design.
- Figure 3 illustrates a typical High Tension metering equipment installation (EO-10215). Fault protection and isolation are provided by the following devices:

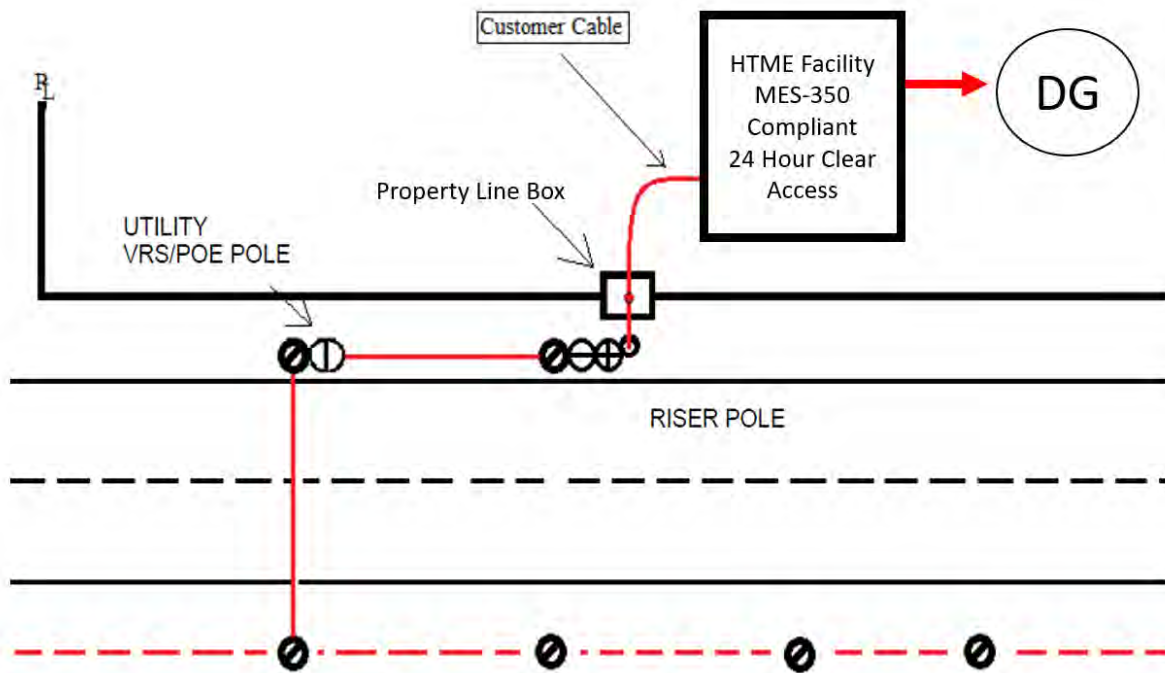

Figure 3 – Example of a High Tension Non-Network Distribution (EO-10215)

References

1. [EO-2022](#) “General Specification for High Tension Service”.
2. [EO-2115](#) “Handbook of General Requirements for Electrical Service to Dispersed Generation Customers”
3. [EO-5051](#) “Design and Construction of 265/460V Transformer Vault and Network Compartments by Contractors
4. [EO-10215](#) “Interconnection Requirements for Distributed Energy Resources (DER) To High Tension Non-Network Distribution”